

Miniaturised wearable UHF-RFID tag with tuning capability

S. Manzari, S. Pettinari and G. Marrocco

By carving a ‘square-smile’ slot profile over a folded patch, a miniaturised UHF-RFID tag is obtained, having a convenient two-step tuning mechanism (coarse and fine). This is useful to adapt the same tag to European and US frequencies and to make on-site corrections. The antenna is half the size of a credit card and can be read up to 5m when attached onto the body. The flexible and lightweight EPDM foam substrate makes the tag suited to be integrated in badges, wallets, pockets, plasters, wristbands and various garments.

Introduction: Radio frequency identification (RFID) and wireless sensor systems are emerging technologies, attracting remarkable interest in security, healthcare, biomedical applications and even entertainment and social arts. Passive devices are particularly attractive for body-centric platforms owing to their light weight, low cost and the absence of battery recharging. In particular, tags integrated into clothes, eventually hosting specific sensors, make it possible to remotely monitor human body activity [1, 2]. In recent years, several on-body passive dipole and patch tags have been presented [3–5] for the UHF (866–956 MHz) RFID frequency, but smaller layouts are however needed in some applications in order to simplify the integration with clothes or plasters. Miniaturisation of wearable passive tags generally produces a remarkable degradation of the antenna bandwidth as well as of the radiation efficiency due to the presence of the lossy human body. As a consequence, this can negatively affect the interoperability in different countries and the stability of the performances with respect to the specific body placement.

Starting from previous experiments of the same authors with wearable tags in [2], this Letter proposes a new layout over a flexible and low-cost substrate with reduced external dimensions. The geometry provides a two-step tuning mechanism that permits in principle to easily adapt the same tag to any frequency inside the world-wide UHF RFID band (866–956 MHz) and even to make finer corrections for the specific placement. The antenna potentiality is here demonstrated by a parametric analysis and measurements on real prototypes.

Antenna layout and miniaturisation procedure: Fig. 1a shows the shape of the proposed tag antenna. The layout is similar to a ‘square smile’ comprising a folded patch (the ‘head’) to achieve a partial decoupling from the human body, connected to the RFID microchip by an H-shaped slot (the ‘glasses’) as in [2]. The form factor of the H-slot provides the required inductive reactance to balance the microchip impedance. The presence of the ‘whisker’ slot (size n) and of the ‘mouth’ (size c) permit us to extend the current path from the microchip terminals towards the radiating edge (Fig. 1b). In this way the electrical length of the antenna increases and hence the antenna’s resonance shifts towards a lower frequency producing miniaturisation. To provide an example of the tuning capability with respect to parameters $\{n, c\}$, the antenna has been simulated by finite difference time-domain modelling considering a microchip impedance $Z_{chip} = 13 - j 151\Omega$ (Impinj Monza 4 IC, power sensitivity: -18dBm) and a 3mm-thick substrate (ethylene-propylene-diene monomer EPDM foam) of dielectric properties $\epsilon_r = 1.21$, $\sigma = 4 \times 10^{-5} \text{ S/m}$. By observing in Fig. 2 the power transfer coefficient

$$\tau = \frac{4R_{chip}R_a}{|Z_{chip} + Z_A|^2} \leq 1 \quad (1)$$

with $Z_A = R_a + jX_a$ input impedance of the antenna, it is worth noting that the variation of mouth and whisker produces only a shift of the optimum frequency, preserving the peak value, which is instead mainly controlled by the shape factor of the H-slot. In particular, changing the size n of the whisker-like slots, a significant and coarse change of the resonance frequency (12.5 MHz/mm) is produced, while adjusting the mouth’s length c , a finer tuning of the resonance is possible (2.5 MHz/mm). Simulations demonstrated that the radiation gain of the miniaturised on-body antenna is almost insensitive to the change of the whisker and mouth parameters and is between -7 and -7.5dB at 868MHz.

The proposed layout therefore offers two-step tuning, which makes it easy to re-adapt the same overall shape of the antenna to different

frequencies and placement over the body. It is indeed seen (Fig. 2b) how the same antenna may be adapted for the European RFID band (866–869MHz) or USA RFID band (902–928 MHz) by just acting on the whisker’s length. In practical applications, the length of mouth and whisker can be easily modified by adding or removing narrow strips of adhesive copper, as shown later on. The resulting external size is about half that the H-slot antenna previously presented by the authors in [2].

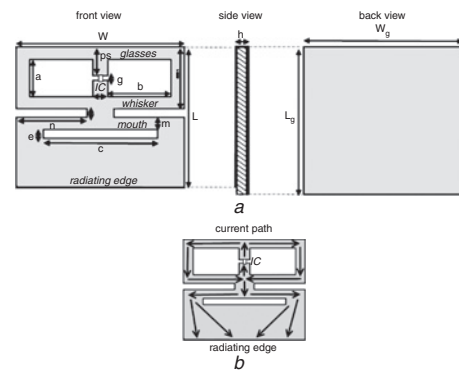

Fig. 1 Layout of miniaturised wearable tag on 3 mm-thick EPDM foam (external size: $L_g = 35\text{mm}$, $W_g = 45\text{mm}$, $h = 3\text{mm}$)

- a Geometry and parameters
- b Schematic path of electric currents over top part of tag

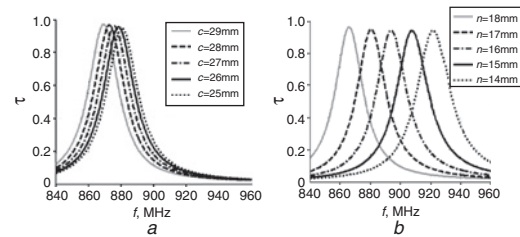

Fig. 2 Parametric exploration of simulated power transmission coefficient for various lengths

- a Mouth parameter ‘ c ’
 - b Whisker parameter ‘ n ’
- Size fixed in mm: $L = 34$; $L_g = 35$; $W = 43$; $W_g = 45$; $a = 9$; $b = 16$; $d = 10$; $e = 2$; $g = 1$; $h = 3$; $i = 15$; $ps = 7$, $m = 3$. Frequency shifts produced by 4mm variation of c and n are 10 and 50MHz, respectively

Prototype and performance: A $4.5 \times 3.5\text{cm}$ prototype of the miniaturised wearable tag (Fig. 3) has been first designed for application at the European RFID frequency $f = 868\text{MHz}$, and hence fabricated by using aluminium adhesive sheet carved by a computer-controlled cutter. The size of this kind of antenna is suitable for integration into ID cards or plasters.

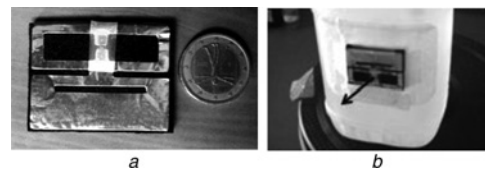

Fig. 3 RFID miniaturised wearable aluminum prototype, over 3mm EPDM black foam having dimensions as reported in Fig. 2 and mouth and whisker parameters $c = 29\text{mm}$, $n = 18\text{mm}$

- a Top view of prototype
- b Prototype placed on human laboratory phantom (arrow indicates direction of realised gain measurements)

A liquid phantom, made by a proper moisture of water, sugar and salt, representing generic human body parts for sizes and dielectric properties ($\epsilon_r = 55.1$, $\sigma = 0.33 \text{ S/m}$), has been used for the electromagnetic characterisation of the prototype. The communication performance of the tag has been experimentally verified with respect to the realised gain $\hat{G}_T = G_T\tau$ measured by means of the turn-on method [6].

In Figs. 4a and b the measured and simulated data refer to the frontal direction (tag and reader antennas are aligned) and are in good

agreement, especially at the reference European frequency 868 MHz, where the realised gain reaches -7 dB. The estimated free-space read range is almost 4 m in the case of the reader with circular polarisation ($\eta_p = 0.5$) and above 5 m in the case of the reader with linear polarisation ($\eta_p = 1$). Nearly identical results have been obtained when the tag was placed directly onto the human body.

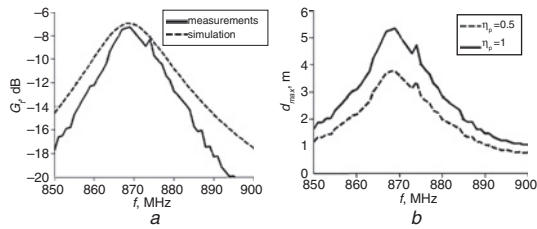

Fig. 4 Measured and simulated realised gain of miniaturised wearable tag in frontal (broadside) direction (Fig. 4a), and estimated maximum read range in free-space for case of reader with circular and linear polarisation (Fig. 4b)

To demonstrate the simple manual tunability of the tag, the previous prototype has been modified with the purpose of moving the peak of the power transfer coefficient towards the US RFID frequency $f = 910$ MHz. As suggested by Fig. 2, the whisker size n has to be shortened by 3 mm (from 18 to 15 mm) and this has been practically achieved by adding two aluminium strips on the whiskers, as shown in Fig. 5. At this point, the size of the mouth may be used for further refinement depending of the specific placement over the body.

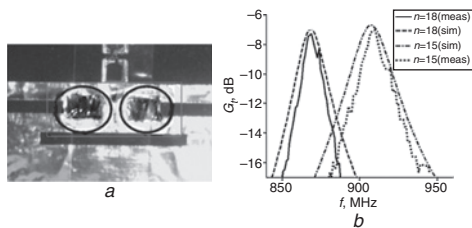

Fig. 5 Wearable prototype with additional strips of aluminium to shorten 'n' from 18 to 15 mm (Fig. 5a), and measured and simulated realised gain for tag in frontal (broadside) direction with n equal to 18 and 15 mm (Fig. 5b)

Conclusions: The proposed miniaturised layout with dimensions comparable to half a credit-card preserves, when placed on-body, reasonable communication performance suitable to in-room tracking. The 'square-smile' geometry provides enough degrees of freedom for a double-step tuning. The tag is suited to be sewn into clothes, plasters or ID cards, and even to host passive sensors for health or human activity monitoring.

© The Institution of Engineering and Technology 2012

21 August 2012

doi: 10.1049/el.2012.2813

S. Manzari, S. Pettinari and G. Marrocco (Pervasive Electromagnetics Lab, University of Roma Tor Vergata, Italy)

E-mail: marrocco@disp.uniroma2.it

References

- 1 Occhiuzzi, C., and Marrocco, G.: 'The RFID technology for neurosciences: feasibility of limbs' monitoring in sleep diseases', *IEEE Trans. Inf. Technol. Biomed.*, 2010, **14**, pp. 37–43
- 2 Occhiuzzi, C., Cippitelli, S., and Marrocco, G.: 'Modeling, design and experimentation of wearable RFID sensor tag', *IEEE Trans. Antennas Propag.*, 2010, **58**, (8), pp. 2490–2498
- 3 Svanda, M., and Polivka, M.: 'Two novel extremely low-profile slotcoupled two-element patch antennas for UHF RFID of people', *Microw. Opt. Technol. Lett.*, 2010, **52**, pp. 249–252
- 4 Kellomaki, T., Bjorninen, T., Ukkonen, L., and Sydänheimo, L.: 'Shirt collar tag for wearable UHF RFID systems'. European Conf. on Antennas and Propagation, (EuCAP), Barcelona, Spain, 2010
- 5 Ukkonen, L., Sydänheimo, L., and Rahmat-Samii, Y.: 'Sewed textile RFID tag and sensor antennas for on-body use'. European Conf. on Antennas and Propagation, (EuCAP), Prague, Czech Republic, 2012
- 6 Amato, F., and Marrocco, G.: 'Self-sensing passive RFID: from theory to tag design – an experimentation'. European Microwave Conf., Roma, Italy, 2009